

System 3000 Installation Manual

MPEG 2 Digital IRD/Data Guide

Version 3.4
21 October 2001



CONTENTS

	Page/s
Introduction	4
• MPEG 2 IRD	
i. Installing your MPEG2 IRD	5 - 7
ii. Setting up your MPEG2 IRD	8 - 11
• Associated Press Printer Interface	
i. Installing your APPI	12 - 14
ii. Script Data Format	15 -17
• Satellite Distribution	
i. Satellite Distribution	19 - 20
• Contact information	21

YOUR
MPEG2
IRD

FOR THE RECEPTION
OF
APTN AND SNTV



MPEG 2 DIGITAL IRD SET-UP

INTRODUCTION

This information is intended as a guide on how to set up your newly delivered MPEG 2 IRD.

The IRD will be shipped with some of the parameters already set for reception of APTN services. In some cases, connecting the IRD and switching it on should result in a good quality reception. However, since individual antenna systems may be different there may be several items within the IRD menus that will need changing. This is explained in detail in the following pages.

As soon as you have received the unit, we would ask that you install the unit into your system.

PLEASE NOTE:

If power is applied to the IRD without the MPEG2 data being transmitted to the satellite then it will not be possible to receive any pictures from this system or store the set-up into the IRD's memory.

At this stage all of the RED ALARM Lamps will light, as there is no MPEG2 input to the unit. Do not worry!

MPEG 2 DIGITAL IRD INSTALLATION

SIMPLE GUIDE

We at APTN have provided you with an NDS system 3000 receiver decoder. It has been configured by our engineers at Associated Press Television News Headquarters to receive our news service via satellite with the minimum input required from yourselves. Please observe the instructions below, and it should provide years of trouble free service.

INSTALLATION:

The supplied unit can be mounted into a standard European 19 inch wide equipment rack. It occupies a height of 2 "U" and requires a generous airflow around itself to keep cool. We suggest leaving a gap of about 1 inch (2.5 cm) around the unit for this purpose.

To make it work the unit requires:

- Mains Electricity
- A signal from a Satellite Dish

All the standard connections are on the rear panel and are as follows:

- **75 Ohm BNC** style plugs (both carry same video signal).
- **Cannon XLR** style plugs (male) for the two audio channels
- **75 Ohm "F" type** R.F. plug for L-band satellite dish signal.
- **IEC** style 3 pin mains connector (100-240v, 50-60Hz mains)

NOTE: The manufacturer recommends that the equipment is connected to a technical earth via the rear panel lug.

Any local technician or engineer can easily connect the receiver up to your existing video installation.

The rear of the unit looks like this:

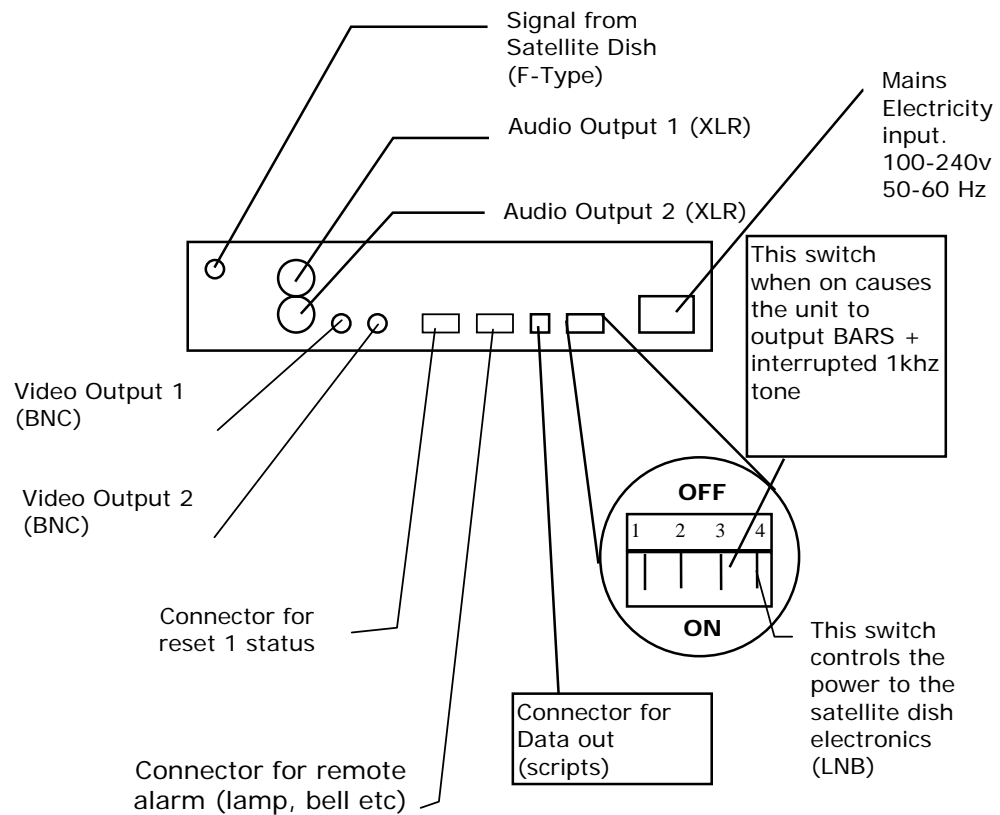

As can be seen from the above diagram, the receiver needs mains electricity. Any voltage between 100 and 240 volts should suffice. (Make sure your supply is "AC").

The satellite dish electronics (LNB) in your dish may require being powered from the receiver itself. This is quite likely if your dish is dedicated to the reception of APTN. If on the other hand the dish is used for other services as well, then it may be likely that the dish electronics (LNB) are already powered from some other piece of equipment.

Please check this with a local technician / engineer with regards to *YOUR* installation, as the setting of "switch 4" on the back of the receiver will be determined by the above requirement. The signal fed into the "F" type connector on the rear of the receiver needs to be in the "L" band region (950 - 2050 MHz) This is a standard signal from a satellite dish. Please be sure to apply the mains electricity to the unit LAST. This will avoid the risk of shorting the "F" type plug during insertion and blowing a fuse!

The Video and Audio outputs from the receiver are industry standard signals

(video 1 volt Pk-Pk / 75Ω, Audio 1mW / 600Ω @ 0 dBm).

FUNCTIONING

Upon powering the receiver, the receivers cooling fan (at the right hand side, viewed from the front) should start to spin. All of the LED's in the column, at the left hand side of the front panel should flash briefly, and then extinguish, all except the green one at the bottom. The green LED is the "Power" LED, and should always be lit. Any red LED's are alarm indicators, and these should not be lit. If any of them are, there maybe a problem.

In the event of any problem, your first course of action is to check that all the cables and connections are correctly made. The second course of action is to check that your satellite dish is still functioning, and that it is still pointing at the correct satellite. We recommend that dishes over 5M in diameter are "station kept" with motorised positioners. If both the above actions do not restore service, then please contact us at APTN (please refer to page 21 for contact information).

INSTRUCTIONS FOR SET-UP OF THE MPEG2 IRD

Note:

Key presses on the remote are indicated by numerals e.g. **1 8 9** or
<EXIT> <ACCESS>

When an item is selected on the screen with the **SELECT** key, that highlighted section will change from yellow to blue. When the change has been made it will change back to yellow

1 With the IRD switched on, and its video output connected to a suitable video monitor, aim the remote control at the IRD and press the following sequence of keys rapidly -

<ACCESS> "the last 3 digits of the IRD serial number"

If this does not work try,

0 0 0 or 2 7 8

The YELLOW "Local Control" Lamp will now light.

Repeat the above process until the Lamp lights. If neither of the above codes work, try <ACCESS> 71931328179. The complete number must be entered within 10 seconds.

2 Now press the **<GUIDE>** key, you will now see a display headed SERVICE GUIDE: ALL SERVICES, at the bottom of the screen, you will see the words TUNER CONTROL, highlighted.

Now press the **<SELECT>** key, this now displays the tuner control screen.

3(i) For **AsiaSat 2** (Figure 2): -

Using the up and down ARROW keys, highlight the text "FREQUENCY", and press the <**SELECT**> key, now enter the APTN Downlink frequency of **3799 MHz** for AsiaSat 2 (100.5degE) with the numeric keys, now press the <**SELECT**> key, this now enters the downlink frequency.

(ii) For **W1** (Figure 3): -

Using the up and down ARROW keys, highlight the text "FREQUENCY", and press the <**SELECT**> key, now enter the APTN downlink frequency of **12625.0MHz** for W1 (10degE) with the numeric keys, now press the <**SELECT**> key, this now enters the down link frequency.

(iii) For **AMC 3** (Figure 4): -

Using the up and down ARROW keys, highlight the text "FREQUENCY", and press the <**SELECT**> key, now enter the APTN Downlink frequency of **3732.5 MHz** for Spacenet 3 (87degW) with the numeric keys, now press the <**SELECT**> key, this now enters the downlink frequency.

(iv) For **PANAMSAT 9** (Figure 5): -

Using the up and down ARROW keys, highlight the text "FREQUENCY", and press the <**SELECT**> key, now enter the APTN downlink frequency of **3907.6 MHz** Panamsat 9 (58degW) with the numeric keys, now press the <**SELECT**> key, this now enters the downlink frequency.

NOTE:

APTN can advise the best satellite for your location.

4 Press the **<MENU>** key, you will now have a display headed MENU, with sub-headings (Figure 6):

RECEIVER SET-UP 1
RECEIVER SET-UP 2
STORED CHANNELS
ALARM RELAY MASK
CONDITIONAL ACCESS

Again using the up/down arrow keys and highlight the text "RECEIVER SET-UP", and press **<SELECT>** key. You now have a page headed "RECEIVER SET-UP", move the up/down arrow keys to highlight the text of LNB LO FREQUENCY and press the **<SELECT>** key, now enter with the numeric keys the value of the Local Oscillator, for example, this could be **11000,11200,11300, or 11475 MHz** for Ku Satellites (Figure 7) or **5150 MHz** for C-Band Satellites (Figure 8) followed by the **<ENTER>** key.

Use the arrow keys and highlight the next item in the list "IF SPECTRUM", and press the **<SELECT>** key, use the left/right arrow keys to change the display to NORMAL for Ku, INVERTED for C-Band, now press the **<SELECT>** key to store the change.

5 Now press the **<GUIDE>** key, if all goes well, the IRD will lock up and any RED alarm Lamps will go out, you will now be displayed the SERVICE GUIDE: ALL SERVICES page, and under the words "PREVIOUS PAGE", will be the word "APTn1" (Figure 1). Use the up/down arrow keys to highlight this and press **<SELECT>**.

This has the action of instructing the IRD to decode the APTN service. If you do not get a "tuner Locked" message, then you must try an alternative LNB LO freq.

6 Now press the <**MENU**> key, and you will see the MENU page displayed, again use the up/down arrow keys and highlight "STORED CHANNELS", you will now have the STORED CHANNELS page (Figure 11), at the bottom of the page are the words "SELECT MEMORY TO UPDATE WITH, now press the number key. Now at the top of the page "M.1) APTN1" will quickly flash as the new settings are stored in the machine.

7 Press the <**INFO**> key and you will now have the "DIAGNOSTIC INFORMATION" page (Figure 12), at half way down the screen there is a value of the "BER", Bit Error Rate, please record the value and notify APTN Customer Support.

8 Now press the <**EXIT**> key, you will now see the APTN picture, and a box with text "RELINQUISH CONTROL?" (Figure 15), use the left/right keys to highlight the word "YES", and now press the <**ENTER**> key. The caption will go away and the Yellow Local Control lamp will go out, and you will hear and see the APTN service.

Note:

If there is no or poor quality RF supplied to the IRD, you will see an On Screen Display appear over a frozen screen displaying "No Service". If you do not subscribe to all the APTN services then occasionally you will also see this on screen display with " No RAS Service" or "Service not entitled"

Finally:

If at any time you are not sure of the procedure or would like help/advice, then please call us at APTN and we will be more than happy to talk you through the procedure (for contact numbers, please refer to page 21).

Associated Press Printer Interface (APPI) Installation Manual



A GUIDE TO INSTALLING YOUR NEW "APPI" ASSOCIATED PRESS PRINTER INTERFACE

This small box of electronics is intended to be connected between your APTN MPEG digital IRD and your Newsroom computer system, or serial input printer. It takes data from the RS232 data output socket at the back of the IRD (9 pin "D" type) and buffers it in order to convert the data into a format suitable for your newsroom computer system. The converted data is fed out of the 25 pin "D" type connector (labelled "port2/printer") on pin 2 (and return via pin 7) in serial format @ 9600 Baud, 8, N, 1. The Data should be of the correct format (ANPA) to connect directly to a serial port on your newsroom computer system.

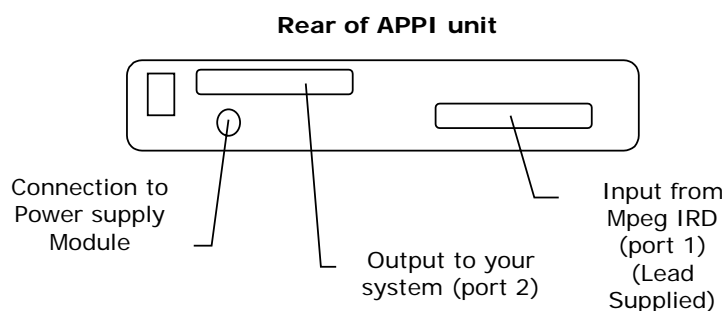

If the "wire services" are not to your requirements, the box's configuration can be changed via an "over the air" download. You may contact us and we can change the configuration for you. Supplied with this unit are:

- **A connecting leads.**
- **A power supply suitable for operation in your territory.**

Note:

More information on the APPI boxes can be found in Appendix A at the back of this manual.

Connection Of IRD to Newsroom Server/Printer via APPI

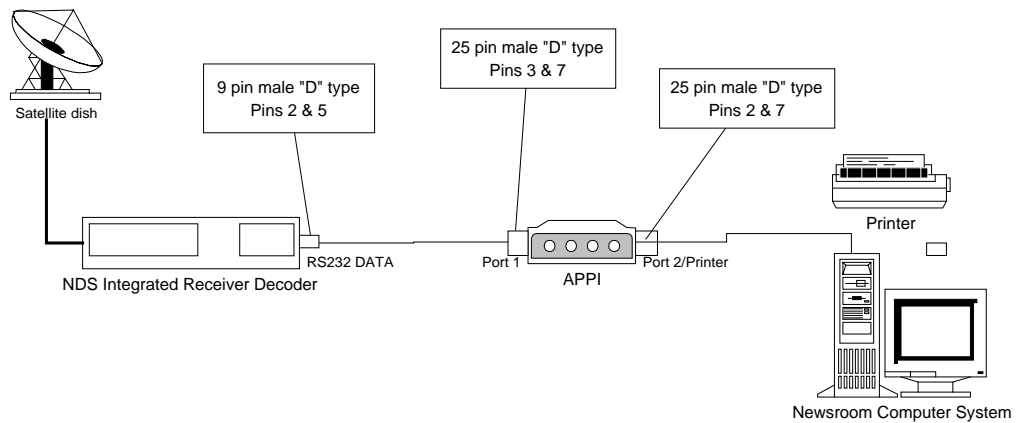

The default data format from the APPI when shipped to you is:

RS232 9600/8/N/1 and is ANPA script format.

The data is sent with the video and audio, so 24hr connection to the IRD must be maintained.

APPI = Associated Press Printer Interface

APPI Script Delivery Format Manual



APTN SCRIPT DELIVERY FORMAT

APTN utilizes the NAA/ANPA and IPTC format structure to deliver scripts to the International Broadcast industry. Data is delivered at 9600bps via a smart interface device called an APPI. This device converts the AP wire feed to the various formats, codes and speeds. Delivery is available at 9600bps (default), 4800bps, 2400bps, and 1200bps. 9600bps is recommended. Data is transmitted with 1 start bit, 8 data bits, no parity, and 1 stop bit. The NAA/ANPA and IPTC format structure is selectable (see Appendix A). The following syntax structure is followed for each format:

NAA/ANPA Format (ANPA Bulletin 1312)

```
<SYN><SYN><SOH>v0000<TFI>{selector}<LF>
{priority}<SP>t<DC2><SP>{Keyword}<SP>{Filing Date}<SP>
{Word Count}<CR><LF>
<STX>
{system addresses, if any}<CR><LF>
^AP-APTN feed start time, if applicable}:{rundown or script name}-
{version}<CR><LF>
{text priority, if applicable, such as ^URGENT< or ^BULLETIN<, then
<CR><LF>}
```

... text ...

{ If a rundown, a feed time is appended, such as
B-u-l-l-e-t-i-n begins at xxxx GMT. }

```
<ETX>{date and time}<EOT>
```

IPTC Format

```
<SOH>v0000<SP>{priority}<SP>txx<SP>{word
count}<SP>{selector}<CR><LF>
{keyword/catch-line}<CR><LF>
<STX>
{system addresses, if any}<CR><LF>
^AP-APTN-{feed start time, if applicable}:{rundown or script name}-
{version}<CR><LF>
{text priority, if applicable, such as ^URGENT< or ^BULLETIN<, then
<CR><LF>}
```

... text ...

{ If a rundown, a feed time is appended, such as
B-u-l-l-e-t-i-n begins at xxxx GMT. }

```
<ETX><EOT>
```

The selector code should be used to identify APTN copy in the remote newsroom computer system. These codes reside in the "selector code field" of the NAA/ANPA and IPTC header.

The selector codes used to identify APTN copy are as follows:

Service	Rundowns	Scripts
Global:	1tvgr	1tvgs
News:	1tvkr	1tvks
Europe:	1tver	1tves
Asia Pacific:	1tvar	1tvas
Australia/New Zealand:	1tvsr	1tvss
Latin America:	1tvlr	1tvls
North America:	1tvnr	1tvns
Arabic:	1tvqr	1tvqs
Roving Report:	1tvtr	1tvts
Entertainment:	1tvbr	1tvbs
Entertainment Voice:	1tvzr	1tvzs
GNS:	1tvfr	1tvfs
Features:	1tvhr	1tvhs
Technology News:	1tvdr	1tvds
SNTV:	1sngr	1sngs
SNTV Arabic:	1snqr	1snqs
AP Newswire:	Asian Wire	V-Wire
EBU:	1tveb	n/a

The priority field identifies the urgency of the story. An APTN item received with a "u" or "b" priority should cause a pop-up and audible alarm in the remote newsroom system. In addition, an item received with a "u" priority should dump into an APTN urgent folder and an item received with a "b" priority should dump into an APTN bulletin folder. Priority codes are used by the remote newsroom systems as follows :

Type	NAA/ANPA	IPTC
Flash (highest, seldom used)	f	1
Bulletin (prime news)	b	2
Urgent (just under prime news)	u	3
Regular (routine)	r	4
Deferred (lowest, delayed sending)	d	5

NOTE: Default Delivery Configuration for APTN

* ANPA Format @ 9600bps, 1 start / 8 data / 1 stop, no parity

* APTN Data should dump into:

1. The "All-wires" folder.
2. Newly created "APTN" folder.
3. "u" priority items into "APTN Urgent" folder.
4. "b" priority items into "APTN Bulletin" folder.

For Arabic transmission, the ASMO 708 Arabic DOS code page is used.

Satellite Distribution



APTN SATELLITE DISTRIBUTION DETAILS

Satellite	Asiasat 2
Orbital Position	100.50 East
APTN Transponder Number	5B
Assigned Bandwidth	9 MHz
Downlink Frequency	3,799 MHz
Downlink Polarisation	Horizontal

Satellite	Eutelsat W1
Orbital Position	10 East
APTN Transponder Number	F4
Assigned Bandwidth	9 MHz
Downlink Frequency	12,629.6 MHz
Downlink Polarisation	Vertical

Satellite	AMC 3
Orbital Position	87.00 West
APTN Transponder Number	1
Assigned Bandwidth	9 MHz
Downlink Frequency	3732.3 MHz
Downlink Polarisation	Horizontal

Satellite	Panamsat 9
Orbital Position	58 West
APTN Transponder Number	11C
Assigned Bandwidth	9 MHz
Downlink Frequency	3907.625 MHz
Downlink Polarisation	Vertical

APTN CUSTOMER SUPPORT

For all queries regarding technical matters APTN provides an efficient client assistance service.

Please contact the APTN Customer Support department with any reception queries or problems.

APTN CUSTOMER SUPPORT TEAM

Tel: +44 (0)20 7410 5220 (09:00 to 17:00GMT)

Fax: +44 (0)20 7410 5388

E-mail: aptn_customer_support@ap.org

Please contact our APTN News Liaison department with any non-technical queries or problems.

APTN NEWS LIAISON

Tel: +44 (0)20 7482 7638 (09:15 to 17:15GMT)

Fax: +44 (0)20 7413 8326

E-mail: aptn_news_liaison@ap.org

At other times, please contact:

APTN's MCR

Tel: +44 (0)20 7482 7575